

SP-401S SOLAR TAXIWAY EDGE LIGHT, TURNING PAD LIGHT



MEDIUM INTENSITY



INDIVIDUAL LIGHT STATUS MONITORING

The S4GA solar runway taxiway edge and turning pad lights provide a permanent, reliable lighting solution for civil and military airports, while also serving as a backup system for airports with wired lighting infrastructure.

KEY FEATURES

- Solar-Powered
- Radio-Controlled
- Individual Light Status Monitoring



TECHNICAL SPECIFICATIONS

Optics	
<ul style="list-style-type: none"> • Color: blue • 11 cd light output (tested by accredited laboratory) • Omnidirectional type • LED lifespan: 100,000 hrs • Maximum power consumption: 0.6 W • NVG-compatible, Infrared LEDs (optional) • User-replaceable 	
Battery	
Lead Acid (Standard)	2x built-in batteries, user-replaceable, air transportable Autonomy: 1080 hrs (30% intensity) Total capacity: 216 Wh (2 x 9 Ah / 12 V) Deep-cycle VRLA, 12 V / 9 Ah (available worldwide) Lifespan: 1,200 cycles (designed for 4-5 years)
Li-ion	2x built-in batteries, user-replaceable, air transportable Autonomy: 2040 hrs (30% intensity) Total capacity: 408 Wh (2 x 17 Ah / 12 V) Li-ion, 12 V / 17 Ah Lifespan: 3,000 cycles (designed for 6-7 years)
LiFePO4	2x built-in batteries, user-replaceable, air transportable Autonomy: 1440 hrs (30% intensity) Total capacity: 288 Wh (2 x 12 Ah / 12 V) LiFePO4, 12 V / 12 Ah Lifespan: 3,000 cycles (designed for 6-7 years)
Lead Acid Cyclon (Arctic Pack)	1x built-in battery, user-replaceable, air transportable Autonomy: 600 hrs (30% intensity) Total capacity: 120 Wh (10 Ah / 12 V) Lifespan: 300 cycles (designed for 10-15 years)
Solar Power Supply	
<ul style="list-style-type: none"> • 25 W solar panel, separately installed • Polycrystalline type (optional: monocrystalline) • Lifespan: 15 years • MPPT-Temp / Built-in inverter 12-36 V / 2 A 	
Control & Monitoring	
Communication	Wireless mesh type network
Frequency	868 MHz (optional 915 MHz, 2.4 GHz)
Wireless range	>10 km (relayed)
Operating modes	Steady / Flashing / Dusk till dawn Visible / Infrared (optional) / Visible + Infrared (optional)
Activation options	Via ALCMS Computer Interface (requires UR-201) Via UR-201 Control & Monitoring Unit Via UR-101 Handheld Controller
Safety & Reliability	
<ul style="list-style-type: none"> • Five levels of protection against system failure • Secondary power supply: backup battery • Real-time monitoring via ALCMS (Airfield Lighting Control and Monitoring System) • Emergency ON/OFF button 	

Casing & Components	
<ul style="list-style-type: none"> • Light body materials Dome: borosilicate hardened glass, UV-resistant Casing: Lexan polycarbonate, UV-stabilized,color: aviation yellow • Mounting components Material: marine grade stainless steel Frangible coupling material: aluminum (tested by accredited laboratory) Type: permanent / quick release (optional) • Charging port: one port / two ports (optional) / drop-in charging port (optional) • Detachable antenna • Pressure stabilizing valve, transportation fuse • Battery level indicator • Carrying handle (optional) • Casing lifespan: 15 years • Dimensions (LxWxH): 557 mm x 450 mm x 358 mm 	
Environmental Conditions	
<ul style="list-style-type: none"> • Temperature range: -20 to 50 °C (-4 to 122 °F) Optional: -40 to 80 °C (-40 to 176 °F) • Ingress Protection: IP-68 (tested by accredited laboratory) • Impact Resistance: IK-10 (tested by accredited laboratory) • Jet Blast Resistance: 240 kph (tested by accredited laboratory) 	
Compliance	
Photometric & Chromaticity	ICAO, Annex 14th, Volume I, 9th Edition dated July 2022, clause 5.3.18.7 & clause 5.3.18.8, Appendix 1, Figure A1-1b
	STAC Certificat de conformité de matériel de balisage aéronautique dated July 2024
Jet Blast Resistance	ICAO Doc 9157 AN901 Aerodrome Design Manual Part 6, 1st Edition dated 2006, clause 3.2.2 & clause 4.9.1
	FAA AC 150/5345-50B dated September 2007, clause 3.2.2
Frangibility	ICAO Doc 9157 AN901 Aerodrome Design Manual Part 6, 1st Edition dated 2006, clause 4.9
	ICAO, Annex 14th, Volume I, 9th Edition dated July 2022, clause 5.3.1.3
	FAA AC 150-5345-46E, clause 3.4.2.1 FAA AC 150/5220-23, clause 3.2
Secondary Power Supply	ICAO, Annex 14th, Volume I, 7th Edition dated July 2016, clauses 8.1.8-8.1.9 & clause 8.1.11
CE Declaration of Conformity	2014/53/EU RED Directive, clauses 3.1a, 3.1b, 3.2
	2011/65/EU ROHS Directive, clause 4.1

TECHNICAL DRAWING

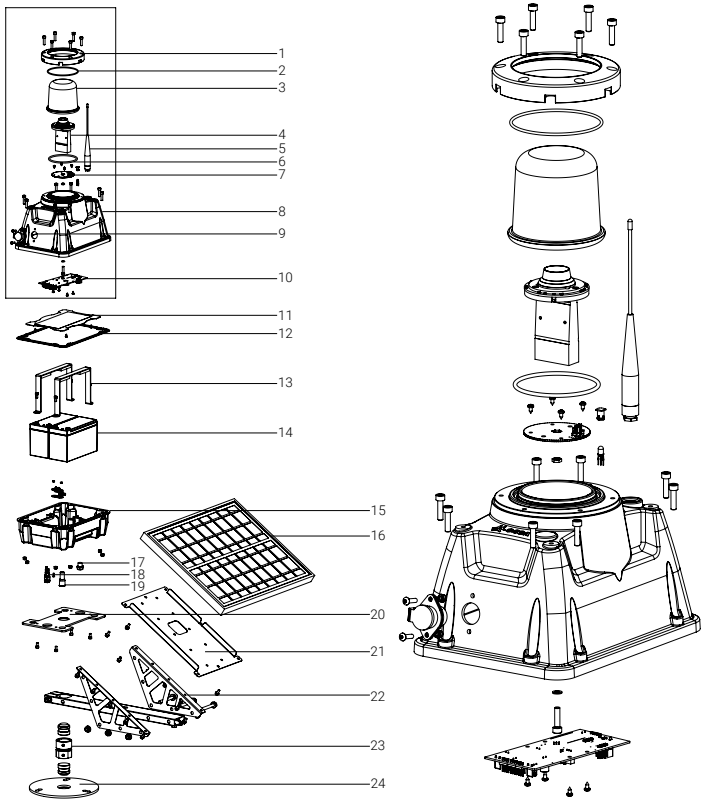

1. Adapter for the glass dome
2. O-ring for the glass dome
3. Glass dome
4. LED optics
5. Radio antenna for wireless control & monitoring
6. O-ring under the glass dome
7. LED PCB
8. Casing (upper part)
9. Charging port
10. Main PCB
11. Protective plate
12. Rubber gasket
13. Battery holder
14. 2x batteries built-in
15. Casing (bottom part)
16. 25 W solar panel with standard optimal inclination
17. Pressure-stabilizing valve
18. Transportation fuse
19. Emergency ON/OFF button
20. Mounting plate
21. Holding frame for solar panel
22. Holder for solar panel frame
23. Frangible coupling
24. Base plate

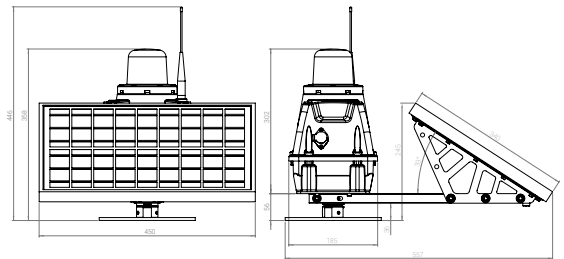

PHOTOMETRIC PERFORMANCE

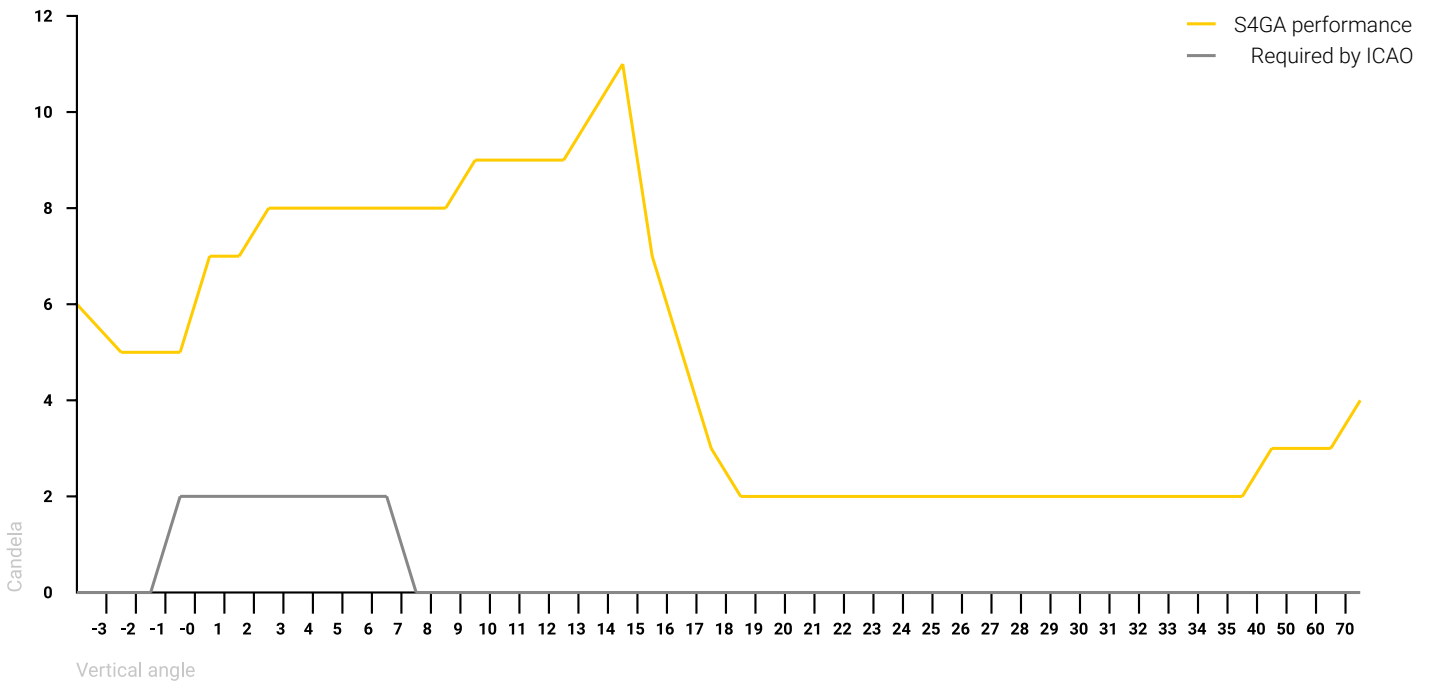

SHIPPING DATA

Item	Dimensions of Package (LxWxH)	Gross Weight
SP-401 Lighting Unit with solar panel and mounting set (NO batteries)	630 mm x 270 mm x 380 mm	10.2 kg
SP-401 Lighting Unit with solar panel and mounting set (Lead Acid batteries)	630 mm x 270 mm x 380 mm	15.0 kg
SP-401 Lighting Unit with solar panel and mounting set (LiFePO4 batteries)	630 mm x 270 mm x 380 mm	12.7 kg
SP-401 Lighting Unit with solar panel and mounting set (Li-ion batteries)	630 mm x 270 mm x 380 mm	12.2 kg