

SP-401P PORTABLE TAXIWAY EDGE LIGHT, TURNING PAD LIGHT



The S4GA portable runway taxiway edge and turning pad lights offer a reliable and versatile solution for temporary and emergency airfield lighting, designed for rapid deployment and efficient operation in all weather conditions.



KEY FEATURES

- Rapid Deployment
- High Operating Time
- Radio-Controlled
- Weather-Resistant



TECHNICAL SPECIFICATIONS

Optics	
<ul style="list-style-type: none"> • Color: blue • 11 cd light output (tested by accredited laboratory) • Omnidirectional • LED lifespan: 100.000 hrs • Maximum power consumption: 0.6 W • NVG-compatible, Infrared LEDs (optional) • User-replaceable 	
Battery	
Lead Acid (Standard)	2x built-in batteries, user-replaceable, air transportable Autonomy: 1080 hrs (30% intensity) Total capacity: 216 Wh (2 x 9 Ah / 12 V) Deep-cycle VRLA, 12 V / 9 Ah (available worldwide) Lifespan: 1,200 cycles (designed for 4-5 years)
Li-ion	2x built-in batteries, user-replaceable, air transportable Autonomy: 2040 hrs (30% intensity) Total capacity: 408 Wh (2 x 17 Ah / 12 V) Li-ion, 12 V / 17 Ah Lifespan: 3,000 cycles (designed for 6-7 years)
LiFePO4	2x built-in batteries, user-replaceable, air transportable Autonomy: 1440 hrs (30% intensity) Total capacity: 288 Wh (2 x 12 Ah / 12 V) LiFePO4, 12 V / 12 Ah Lifespan: 3,000 cycles (designed for 6-7 years)
Lead Acid Cyclon (Arctic Pack)	1x built-in battery, user-replaceable, air transportable Autonomy: 600 hrs (30% intensity) Total capacity: 120 Wh (10 Ah / 12 V) Lifespan: 300 cycles (designed for 10-15 years)
Charging	
<ul style="list-style-type: none"> • Via OCT-401 Charger (charging time: 8 hrs) • Drop-in charging in a Trailer (charging time: 8 hrs) • Optional: solar panel charging for off-grid operation 	
Control & Monitoring	
Communication	Wireless mesh type network
Frequency	868 MHz (optional 915 MHz, 2.4 GHz)
Wireless range	>10 km (relayed)
Operating modes	Steady / Flashing / Dusk till dawn Visible / Infrared (optional) / Visible + Infrared (optional)
Activation options	Via UR-101 Handheld Controller Via UR-201 Control & Monitoring Unit Via ALCMS Computer Interface (requires UR-201)

Safety & Reliability	
<ul style="list-style-type: none"> • Five levels of protection against system failure • Secondary power supply: backup battery • Real-time monitoring via ALCMS (Airfield Lighting Control and Monitoring System) • Emergency ON/OFF button 	
Casing & Components	
<ul style="list-style-type: none"> • Light body materials Dome: borosilicate hardened glass, UV-resistant Casing: Lexan polycarbonate, UV-stabilized, color: aviation yellow • Mounting options Frangible mounting for asphalt / concrete surface Rubber pad for all types surface Type: quick release / permanent (optional) • Charging port: one port / two ports (optional) / drop-in charging port (optional) • Detachable antenna • Pressure stabilizing valve, transportation fuse • Battery level indicator • Carrying handle: aluminium • Casing lifespan: 15 years • Dimensions (LxWxH): 244 mm x 185 mm x 297 mm 	
Environmental Conditions	
<ul style="list-style-type: none"> • Temperature range: -20 to 50 °C (-4 to 122 °F) Optional: -40 to 80 °C (-40 to 176 °F) • Ingress Protection: IP-68 (tested by accredited laboratory) • Impact Resistance: IK-10 (tested by accredited laboratory) 	
Compliance	
Photometric & Chromaticity	ICAO, Annex 14th, Volume I, 9th Edition dated July 2022, clause 5.3.18.7 & clause 5.3.18.8, Appendix 1, Figure A1-1b STAC Certificat de conformité de matériel de balisage aéronautiqu dated July 2024
Secondary Power Supply	ICAO, Annex 14th, Volume I, 7th Edition dated July 2016, clauses 8.1.8-8.1.9 & clause 8.1.11
CE Declaration of Conformity	2014/53/EU RED Directive, clauses 3.1a, 3.1b, 3.2 2011/65/EU ROHS Directive, clause 4.1

TECHNICAL DRAWING

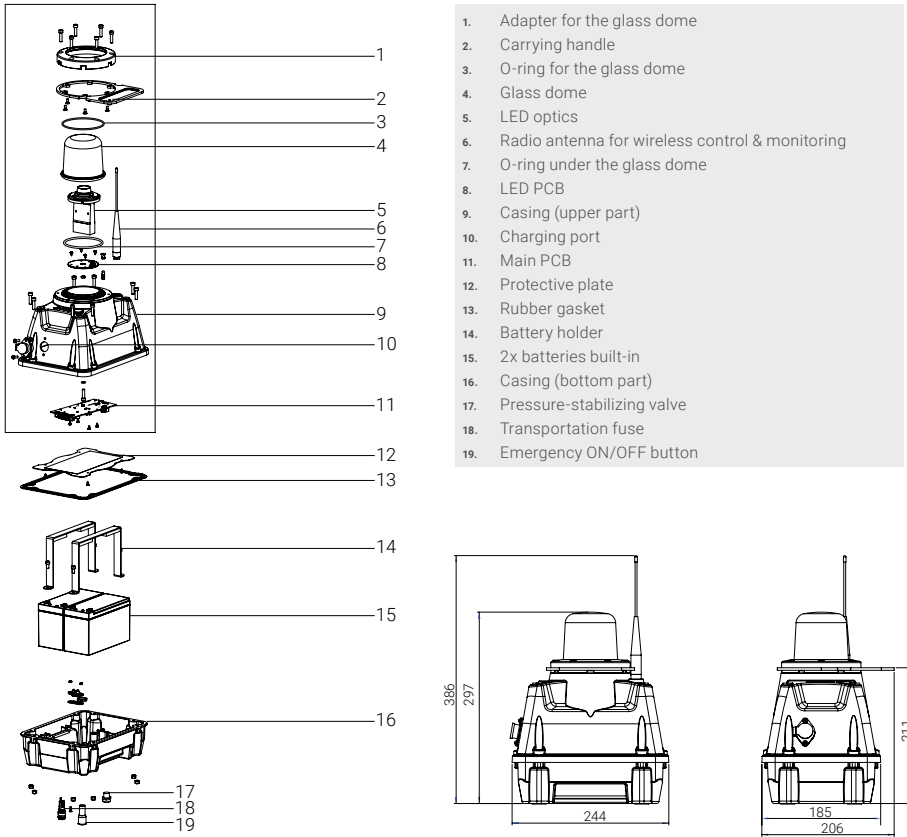

PHOTOMETRIC PERFORMANCE

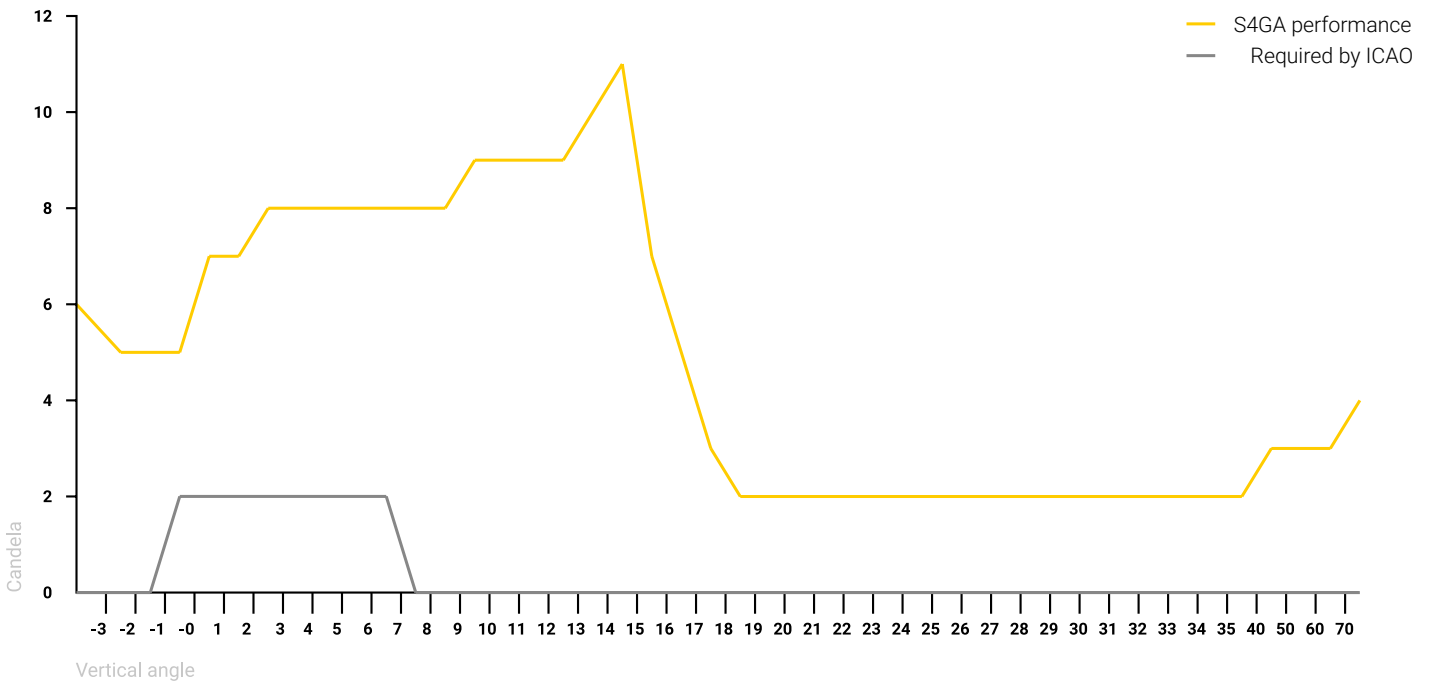

SHIPPING DATA

Item	Dimensions of Package (LxWxH)	Gross Weight
SP-401 Lighting Unit (NO batteries)	630 mm x 270 mm x 380 mm	3.5 kg
SP-401 Lighting Unit (Lead Acid batteries)	630 mm x 270 mm x 380 mm	8.3 kg
SP-401 Lighting Unit (LiFePO4 batteries)	630 mm x 270 mm x 380 mm	6 kg
SP-401 Lighting Unit (Li-ion batteries)	630 mm x 270 mm x 380 mm	5.5 kg