

SP-401P PORTABLE RUNWAY EDGE LIGHT



The S4GA portable airfield light offers a reliable and versatile solution for temporary and emergency airfield lighting, designed for rapid deployment and efficient operation in all weather conditions.



KEY FEATURES

- Rapid Deployment
- High Operating Time
- Radio-Controlled
- Weather-Resistant



TECHNICAL SPECIFICATIONS

Optics	
	<ul style="list-style-type: none"> • Color: white/white/white • 1.200 cd light output (tested by accredited laboratory) • Combined type, omnidirectional and bidirectional • LED lifespan: 100.000 hrs • Maximum power consumption: 9 W • NVG-compatible, Infrared LEDs (optional) • User-replaceable
Battery	
Lead Acid (Standard)	2x built-in batteries, user-replaceable, air transportable Autonomy: 180 hrs (30% intensity) Total capacity: 216 Wh (2 x 9 Ah / 12 V) Deep-cycle VRLA, 12 V / 9 Ah (available worldwide) Lifespan: 1,200 cycles (designed for 4-5 years)
Li-ion	2x built-in batteries, user-replaceable, air transportable Autonomy: 340 hrs (30% intensity) Total capacity: 408 Wh (2 x 17 Ah / 12 V) Li-ion, 12 V / 17 Ah Lifespan: 3,000 cycles (designed for 6-7 years)
LiFePO4	2x built-in batteries, user-replaceable, air transportable Autonomy: 240 hrs (30% intensity) Total capacity: 288 Wh (2 x 12 Ah / 12 V) LiFePO4, 12 V / 12 Ah Lifespan: 3,000 cycles (designed for 6-7 years)
Lead Acid Cyclon (Arctic Pack)	1x built-in battery, user-replaceable, air transportable Autonomy: 100 hrs (30% intensity) Total capacity: 120 Wh (10 Ah / 12 V) Lifespan: 300 cycles (designed for 10-15 years)
Charging	
	<ul style="list-style-type: none"> • Via OCT-401 Charger (charging time: 8 hrs) • Drop-in charging in a Trailer (charging time: 8 hrs) • Optional: solar panel charging for off-grid operation
Control & Monitoring	
Communication	Wireless mesh type network
Frequency	868 MHz (optional 915 MHz, 2.4 GHz)
Wireless range	>10 km (relayed)
Operating modes	Steady / Flashing / Dusk till dawn Visible / Infrared (optional) / Visible + Infrared (optional)
Activation options	Via UR-101 Handheld Controller Via UR-201 Control & Monitoring Unit Via ALCMS Computer Interface (requires UR-201)

Safety & Reliability	
	<ul style="list-style-type: none"> • Five levels of protection against system failure • Secondary power supply: backup battery • Real-time monitoring via ALCMS (Airfield Lighting Control and Monitoring System) • Emergency ON/OFF button
Casing & Components	
	<ul style="list-style-type: none"> • Light body materials Dome: borosilicate hardened glass, UV-resistant Casing: Lexan polycarbonate, UV-stabilized,color: aviation yellow • Mounting options Frangible mounting for asphalt / concrete surface Rubber pad for all types surface Type: quick release / permanent (optional) • Charging port: one port / two ports (optional) / drop-in charging port (optional) • Detachable antenna • Pressure stabilizing valve, transportation fuse • Battery level indicator • Carrying handle: aluminium • Casing lifespan: 15 years • Dimensions (LxWxH): 244 mm x 185 mm x 297 mm
Environmental Conditions	
	<ul style="list-style-type: none"> • Temperature range: -20 to 50 °C (-4 to 122 °F) Optional: -40 to 80 °C (-40 to 176 °F) • Ingress Protection: IP-68 (tested by accredited laboratory) • Impact Resistance: IK-10 (tested by accredited laboratory)
Compliance	
Photometric & Chromaticity	ICAO, Annex 14th, Volume I, 9th Edition dated July 2022, clause 5.3.9.8 & clause 5.3.9.9, Appendix 1, Figure A1-1b STAC Certificat de conformité de matériel de balisage aéronautiqu dated July 2024
Secondary Power Supply	ICAO, Annex 14th, Volume I, 7th Edition dated July 2016, clauses 8.1.8-8.1.9 & clause 8.1.11
CE Declaration of Conformity	2014/53/EU RED Directive, clauses 3.1a, 3.1b, 3.2 2011/65/EU ROHS Directive, clause 4.1

TECHNICAL DRAWING

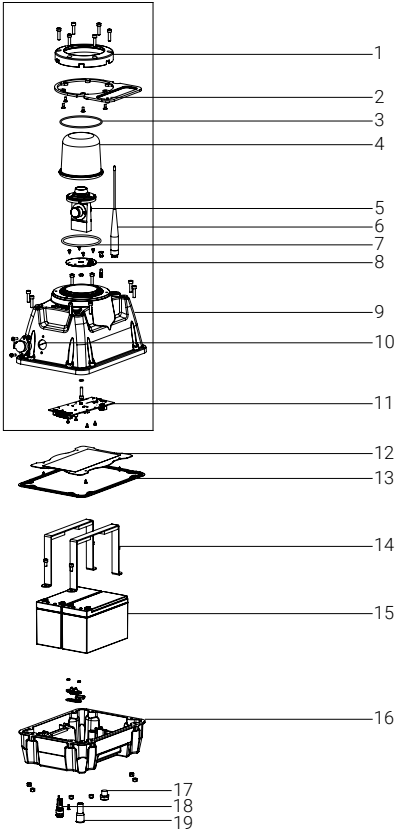

1. Adapter for the glass dome
2. Carrying handle
3. O-ring for the glass dome
4. Glass dome
5. LED optics
6. Radio antenna for wireless control & monitoring
7. O-ring under the glass dome
8. LED PCB
9. Casing (upper part)
10. Charging port
11. Main PCB
12. Protective plate
13. Rubber gasket
14. Battery holder
15. 2x batteries built-in
16. Casing (bottom part)
17. Pressure-stabilizing valve
18. Transportation fuse
19. Emergency ON/OFF button

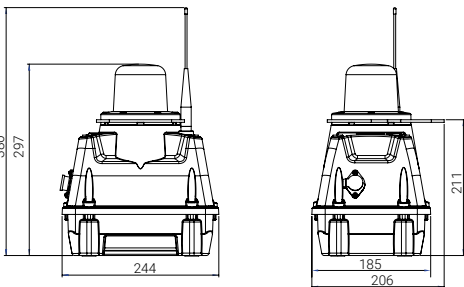

PHOTOMETRIC PERFORMANCE

White

																				SP-401 RUNWAY EDGE LIGHT (WHITE)																					
																				TEST AREA	REQUIRED	RESULTS																			
12"	-	-	-	-	-	-	-	-	-	-	-	-	-	-	-	-	-	-	-	-	AREA 1 (BLUE PART)	MIN. 25 CD AVERAGE MIN. 50 CD	MIN. 818,43 CD AVG. 1069,00 CD																		
11,5"	-	-	-	-	-	-	-	-	-	-	-	-	-	-	-	-	-	-	-	-	AREA 2 (YELLOW PART)	MIN. 10 CD	MIN. 553,26 CD																		
11"	-	-	-	-	-	-	-	-	-	-	-	-	-	-	-	-	-	-	-	-	AREA 3 (PINK PART)	MIN. 5 CD	MIN. 286,85 CD																		
10,5"	-	-	-	-	-	-	-	-	-	-	-	-	-	-	-	-	-	-	-	-																					
10"	-	-	-	-	-	-	-	-	-	-	-	-	-	-	-	-	-	-	-	-																					
9,5"	-	-	-	-	-	-	-	-	-	-	-	-	-	-	-	-	-	-	-	-																					
9"	-	-	-	-	-	-	-	-	-	-	-	-	-	-	-	-	-	-	-	-																					
8,5"	-	-	-	-	-	-	-	-	-	-	-	-	-	-	-	-	-	-	-	-																					
8"	-	-	-	-	-	-	-	-	-	-	-	-	-	-	-	-	-	-	-	-																					
7,5"	-	-	-	-	-	-	-	-	-	-	-	-	-	-	-	-	-	-	-	-																					
7"	-	-	-	-	-	-	-	-	-	-	-	-	-	-	-	-	-	-	-	-																					
6,5"	-	-	-	-	-	-	-	-	-	-	-	-	-	-	-	-	-	-	-	-																					
6"	-	-	-	-	-	-	-	-	-	-	-	-	-	-	-	-	-	-	-	-																					
5,5"	-	-	-	-	-	-	-	-	-	-	-	-	-	-	-	-	-	-	-	-																					
5"	-	-	-	-	-	-	-	-	-	-	-	-	-	-	-	-	-	-	-	-																					
4,5"	-	-	-	-	-	-	-	-	-	-	-	-	-	-	-	-	-	-	-	-																					
4"	-	-	-	-	-	-	-	-	-	-	-	-	-	-	-	-	-	-	-	-																					
3,5"	-	-	-	-	-	-	-	-	-	-	-	-	-	-	-	-	-	-	-	-																					
3"	-	-	-	-	-	-	-	-	-	-	-	-	-	-	-	-	-	-	-	-																					
2,5"	-	-	-	-	-	-	-	-	-	-	-	-	-	-	-	-	-	-	-	-																					
2"	-	-	-	-	-	-	-	-	-	-	-	-	-	-	-	-	-	-	-	-																					
1,5"	-	-	-	-	-	-	-	-	-	-	-	-	-	-	-	-	-	-	-	-																					
1"	-	-	-	-	-	-	-	-	-	-	-	-	-	-	-	-	-	-	-	-																					
0,5"	-	-	-	-	-	-	-	-	-	-	-	-	-	-	-	-	-	-	-	-																					
0"	-	-	-	-	-	-	-	-	-	-	-	-	-	-	-	-	-	-	-	-																					
V/H	10	9,5	-9	-8,5	-8	-7,5	-7	-6,5	-6	-5,5	-5	-4,5	-4	-3,5	-3	-2,5	-2	-1,5	-1	-0,5	0	0,5	1	1,5	2	2,5	3	3,5	4	4,5	5	5,5	6	6,5	7	7,5	8	8,5	9	9,5	10

SHIPPING DATA

Item	Dimensions of Package (LxWxH)	Gross Weight
SP-401 Lighting Unit (NO batteries)	630 mm x 270 mm x 380 mm	3.5 kg
SP-401 Lighting Unit (Lead Acid batteries)	630 mm x 270 mm x 380 mm	8.3 kg
SP-401 Lighting Unit (LiFePO4 batteries)	630 mm x 270 mm x 380 mm	6 kg
SP-401 Lighting Unit (Li-ion batteries)	630 mm x 270 mm x 380 mm	5.5 kg